

# BERLIN

## TBV123-FB

Fly Bar for TBV123 and TBV118L Flown and Ground Stacked Arrays



- Fly bar for suspending TBV123 constant curvature line array elements and TBV118L subwoofers
- Inverts to ground stack TBV123 arrays
- Steel construction with corrosion resistant semi matt black finish
- Multiple pick points for suspension at desired angle
- 3-Year Warranty Program\*
- Designed and engineered in the U.K.

The TBV123-FB Flybar is designed to safely suspend or ground stack TBV123 constant curvature line arrays and TBV118L subwoofers. Engineered to meet BGV-C1 specifications, the flybar can suspend up to 4 TBV123 elements or 2 TBV118L Subwoofers in unique arrays, or 1 subwoofers and 2 elements in a mixed array with a safety factor of 10:1. The flybar is secured to the uppermost speaker enclosure using the supplied drop links and rigging pins, with additional enclosures attaching in a similar manner below in succession.



EASE GLL files are provided for EASE Focus Acoustic Simulation Software, which is available for free download. This allows accurate calculation of both acoustic coverage and suspension pick point selection for tilting and aiming the array at the desired angle. Multiple pick points are provided for shackles up to 3/4" in size, which can be utilised in either single- or two-point suspension configurations.

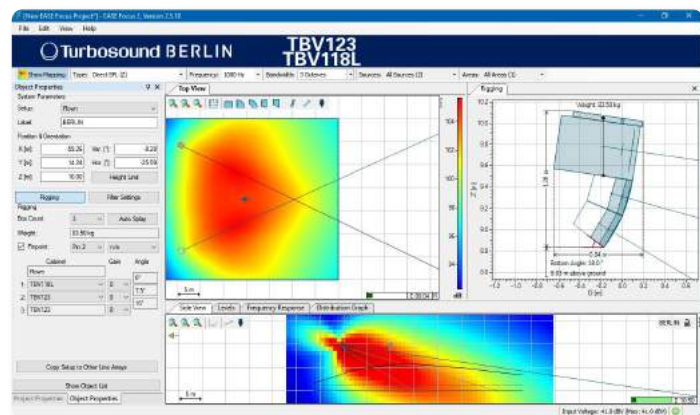

# BERLIN

## TBV123-FB

Fly Bar for TBV123 and TBV118L Flown and Ground Stacked Arrays

### You Are Covered

We always strive to provide the best possible Customer Experience. Our products are made in our own MUSIC Group factory using state-of-the-art automation, enhanced production workflows and quality assurance labs with the most sophisticated test equipment available in the world. As a result, we have one of the lowest product failure rates in the industry, and we confidently back it up with a generous 5-Year Warranty program.



Loudspeaker Accessories

# BERLIN

## TBV123-FB

Fly Bar for TBV123 and TBV118L Flown and Ground Stacked Arrays

### Dimensions

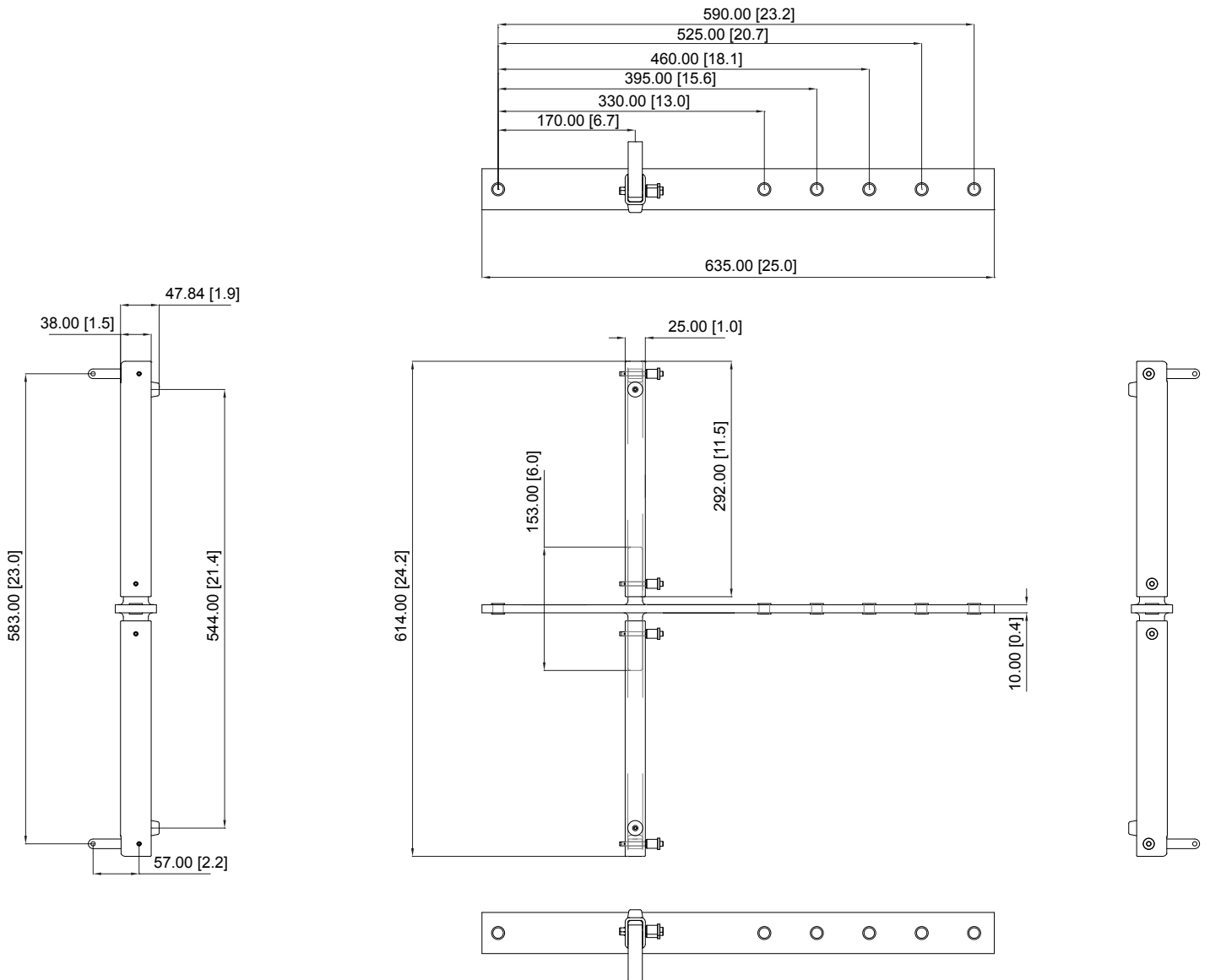

# BERLIN

## TBV123-FB

Fly Bar for TBV123 and TBV118L Flown and Ground Stacked Arrays

### Mounting and Rigging

**⚠ Safety Warning:** Only authorised and certified personnel shall design and install suspended or ground stack configurations, following the instructions and procedures in the TBV123-FB rigging manual supplied with the TBV123-FB flybar, or downloaded from [turbosound.com](http://turbosound.com). Failure to follow these instructions may lead to death or permanent injury. For maximum array sizes, weights and working load limits, please consult the TBV123-FB rigging manual.

The TBV123-FB flybar is used to suspend TBV123, TBV123-AN, TBV118L, and TBV118L-AN cabinets, or mixed arrays of each. Each cabinet has 2 mounting links that connect to corresponding mounting holes in the TBV123-FB flybar, and are secured together using 2 rigging pins supplied with the flybar. Before use the flybar must be assembled by securing the side arms to the main bar using the supplied rigging pins. The main arm of the flybar has five fly points and one at the front. These 13 mm diameter holes are used to attach a bow shackle or similar lifting equipment for flying the assembly. The TBV123-FB flybar may be inverted to form the base for a ground stack array of TBV123 or TBV123-AN cabinets with extra hardware supplied. Cabinets may also be suspended inverted.

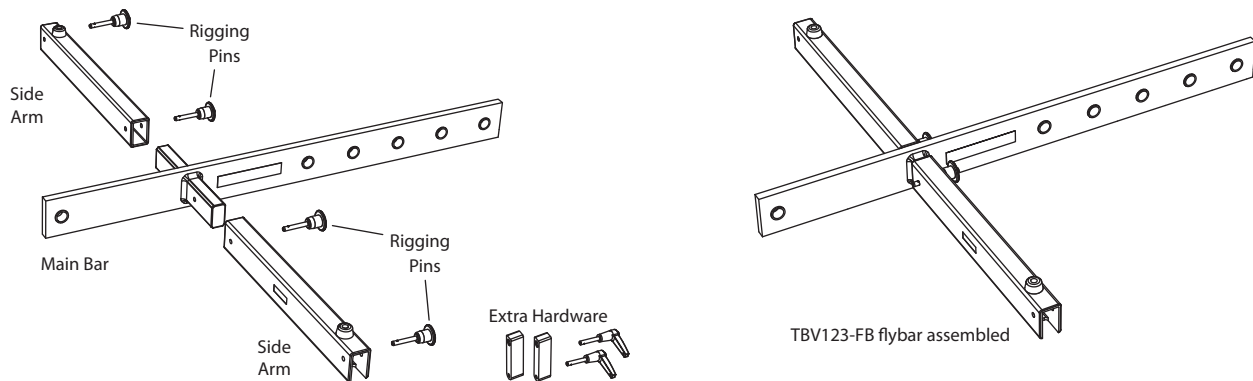

# BERLIN

## TBV123-FB

Fly Bar for TBV123 and TBV118L Flown and Ground Stacked Arrays

### Mounting and Rigging

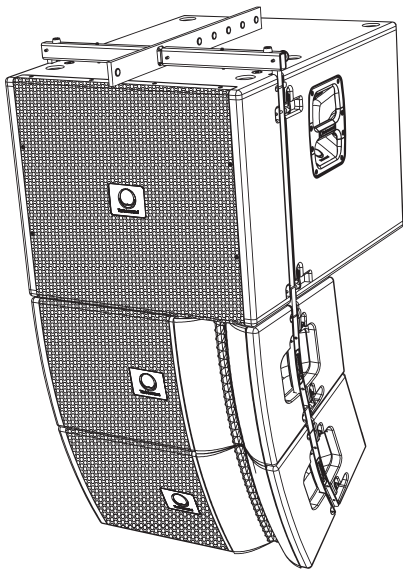

Mixed array with a TBV123-FB flybar, TBV118L subwoofer, and 2 TBV123 cabinets

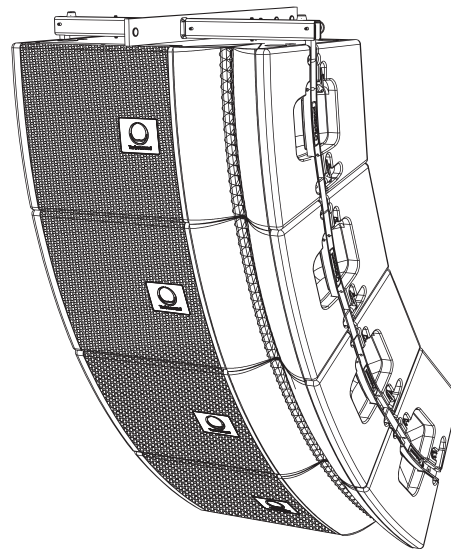

An array of 4 TBV123 cabinets with a TBV123-FB flybar

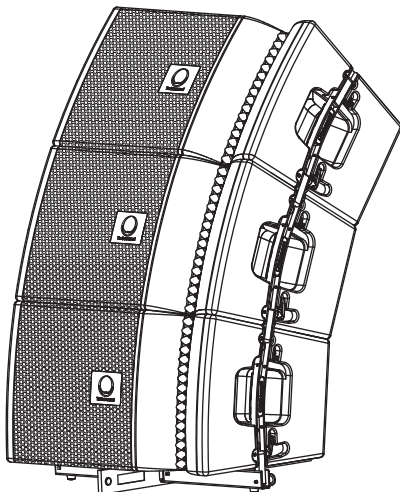

TBV123 array ground stack with an inverted TBV123-FB flybar

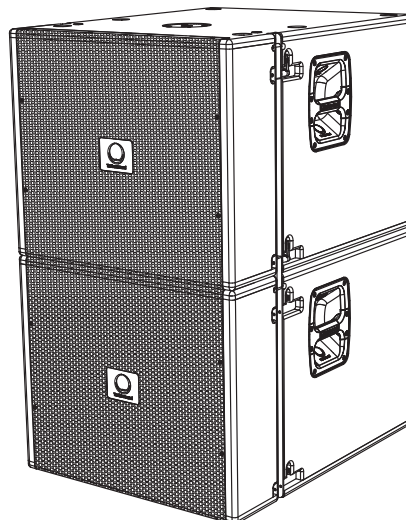

TBV118L ground stack

# BERLIN

## TBV123-FB

Fly Bar for TBV123 and TBV118L Flown and Ground Stacked Arrays



# BERLIN

## TBV123-FB

Fly Bar for TBV123 and TBV118L Flown and  
Ground Stacked Arrays



# BERLIN

## TBV123-FB

Fly Bar for TBV123 and TBV118L Flown and  
Ground Stacked Arrays





# BERLIN

## TBV123-FB

Fly Bar for TBV123 and TBV118L Flown and Ground Stacked Arrays



For service, support or more information contact the TURBOSOUND location nearest you:

**Europe**  
**MUSIC Group Services UK**  
Tel: +44 156 273 2290  
Email: CARE@music-group.com

**USA/Canada**  
**MUSIC Group Services NV Inc.**  
Tel: +1 702 800 8290  
Email: CARE@music-group.com

**Japan**  
**MUSIC Group Services JP K.K.**  
Tel: +81 3 6231 0454  
Email: CARE@music-group.com

MUSIC Group accepts no liability for any loss which may be suffered by any person who relies either wholly or in part upon any description, photograph, or statement contained herein. Technical specifications, appearances and other information are subject to change without notice. All trademarks are the property of their respective owners. MIDAS, KLARK TEKNIK, LAB GRUPPEN, LAKE, TANNÖY, TURBOSOUND, TC ELECTRONIC, TC HELICON, BEHRINGER, BUGERA and DDA are trademarks or registered trademarks of MUSIC Group IP Ltd.  
© MUSIC Group IP Ltd. 2017 All rights reserved.